

# RPR-22PS

*Elite Solid State*

# PULSE ISOLATION RELAY INSTRUCTION SHEET

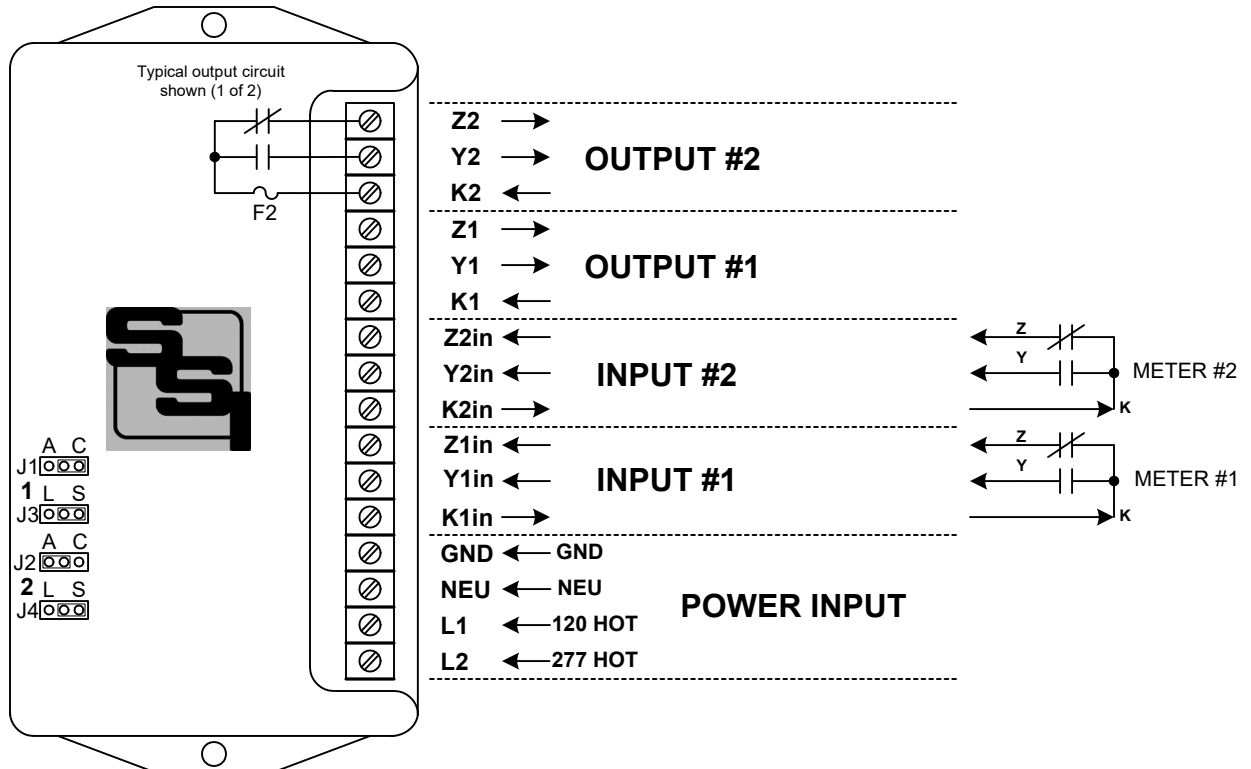

**MOUNTING POSITION** - The RPR-22PS may be mounted in any position.

**POWER INPUT** - For a power supply of 120VAC, connect the AC line's "hot" wire to the **L1** terminal. For 208 thru 277VAC, connect the AC line's "hot" wire to the **L2** terminal. The AC line's "neutral" wire should be connected to the **N** terminal. Connect the **G** terminal to the electrical system ground.

**INPUT CONNECTIONS** - Connect the K terminal of each meter which is supplying pulses to the RPR-22PS to the RPR-22PS' **K1in** and **K2in** terminals. Connect each meter's Y and Z terminals to the respective meter's **Yin** and **Zin** input terminals of the RPR-22PS.

**INPUT TYPE SELECTION** - The RPR-22PS' inputs may be configured as either 2-Wire (Form A) or 3-Wire (Form C). Selector Jumper J1 selects the input configuration for INPUT #1. Selector Jumper J2 sets the input configuration for INPUT #2. Place the Jumper Plug in the correct position for the input type desired: Left-to-center pins for Form A (2-Wire), or right-to-center pins for Form C (3-Wire). Inputs are marked "A" and "C" above the pins.

**FUSES** - The fuses are type 3AG and may be up to 1/2 Amp in size. Two 1/2 Amp fuses (F1 & F2) are supplied standard with the unit unless otherwise specified.

**OUTPUTS** - Two 3-wire isolated outputs are provided on the RPR-22PS, with output terminals K1, Y1 & Z1 and K2, Y2, & Z2. Arc suppression for the contacts of the solid-state relays is provided internally. Each relay channel's input and output are independent and isolated from the other. Inputs may be paralleled if a "splitting" or duplicating relay function is desired.

**OUTPUT TIMING** - Outputs can be configured as "Long" or "Short" duration. In the Long (L) mode, the output duration is the same as the input pulse length creating a "mirror image" output pulse. In the short (S) mode the output is fixed at approximately 100ms in length. This mode is generally used for Form A end-of-interval (EOI) pulses. Connect left-to-center pins for Long(L), or right-to-center pins for Short(S).



## SOLID STATE INSTRUMENTS

by Radian Research, Inc

3852 Fortune Dr, Lafayette, IN 47905

Phone: (765) 449-5576

Mail: [technicalsupport@radianresearch.com](mailto:technicalsupport@radianresearch.com)

# RPR-22PS Wiring Diagram

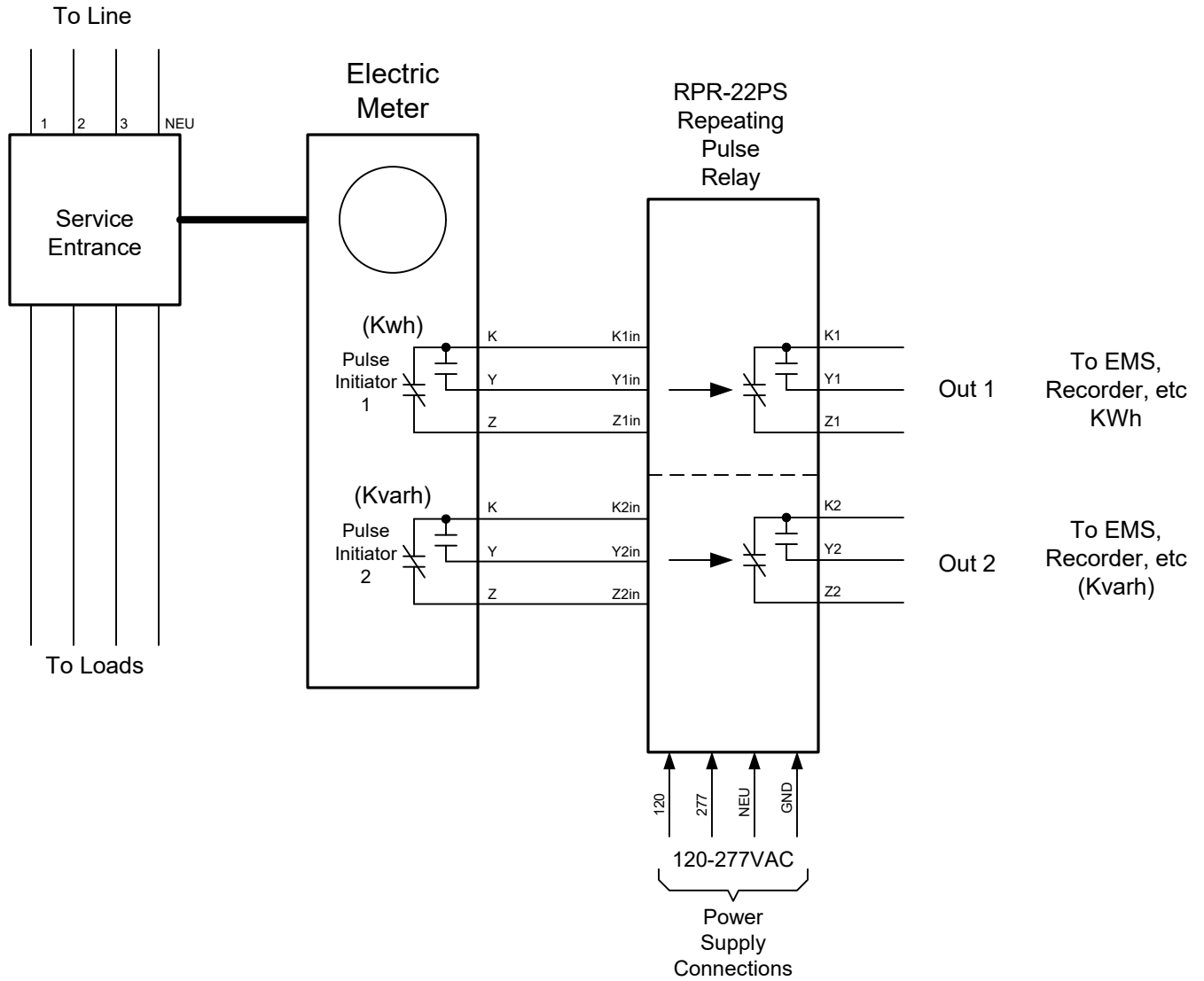

RPR-22PS Repeating Pulse Relay Wiring Diagram		REVISIONS	
		NO.	DATE
DATE ORIGINAL	SCALE		
01/01/25	N/A		
LATEST REVISION	JOB NO.	CHECKED	DRAWN
			WHB

**Solid State Instruments  
by Radian Research Inc**  
 3852 Fortune Dr  
 Lafayette, IN 47905  
 (765) 449-5576  
 technicalsupport@radianresearch.com  
 www.solidstateinstruments.com